

UNIT MEASUREMENTS

- Custom Widths up to 20'
- Custom Heights up to 12'

FABRIC CHOICES

- Screens Fabrics
- Black Out Fabrics
- Clear Vinyl



MANUAL

Gear



5.5" Extruded Aluminum Box



Hand Brace



48" | 60" | 72" | 84" | 96"

Fabric Retention Track (FRT)
see page 4

.5" Pile Brush see page 4

HARDWARE COLORS



BLACK



DESERT SAND



BROWN



WHITE

BOX COLORS



WHITE



IVORY



LT. BEIGE



DK. BEIGE



SAND



BRONZE



GREY



BLACK

Motorized

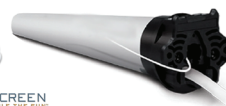

UPGRADE *Options*

FRONT VIEW

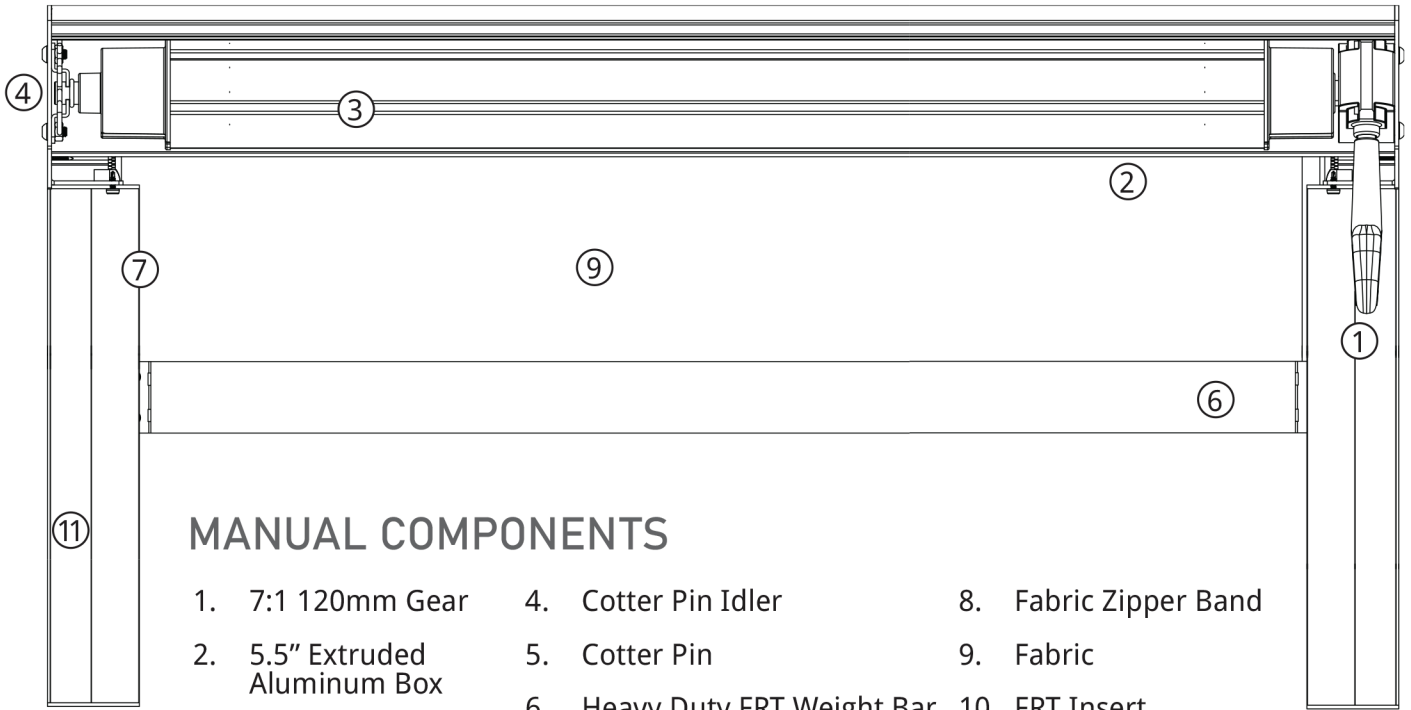

MANUAL COMPONENTS

- | | | |
|-------------------------------|------------------------------|-----------------------|
| 1. 7:1 120mm Gear | 4. Cotter Pin Idler | 8. Fabric Zipper Band |
| 2. 5.5" Extruded Aluminum Box | 5. Cotter Pin | 9. Fabric |
| 3. 80mm Fabric Tube | 6. Heavy Duty FRT Weight Bar | 10. FRT Insert |
| | 7. Heavy Duty FRT Track | 11. Snap Cover |

SIDE VIEW

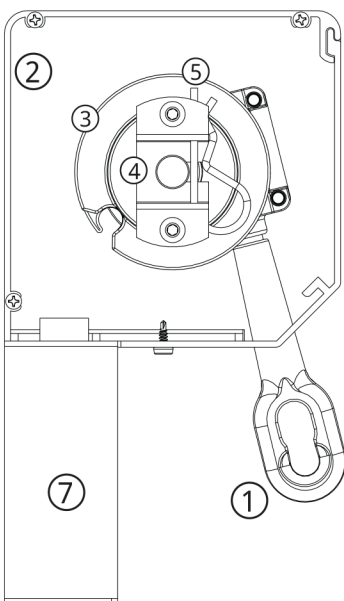

HEAVY DUTY FRT TRACK

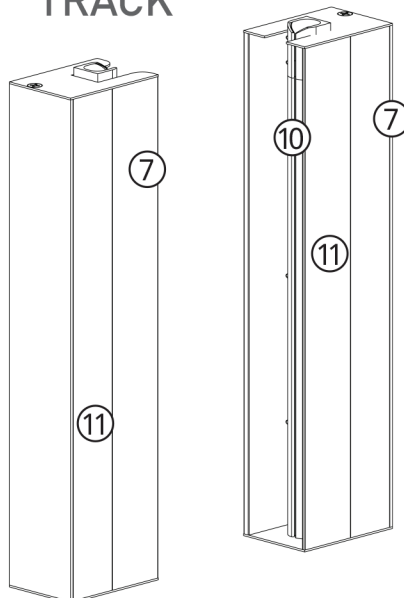

HEAVY DUTY FRT WEIGHT BAR

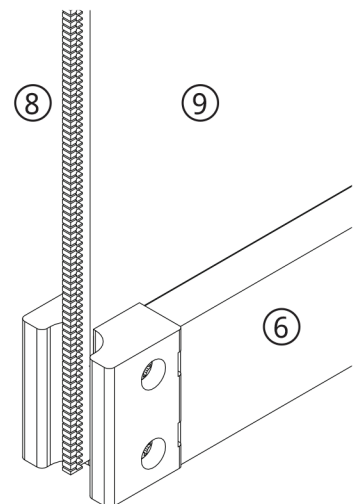

EXPLODED VIEW

1. Top Back Box Piece
2. Box Hood
3. End Cap
4. End Cap
5. 7:1 120mm Gear
6. Cotter Pin Idler

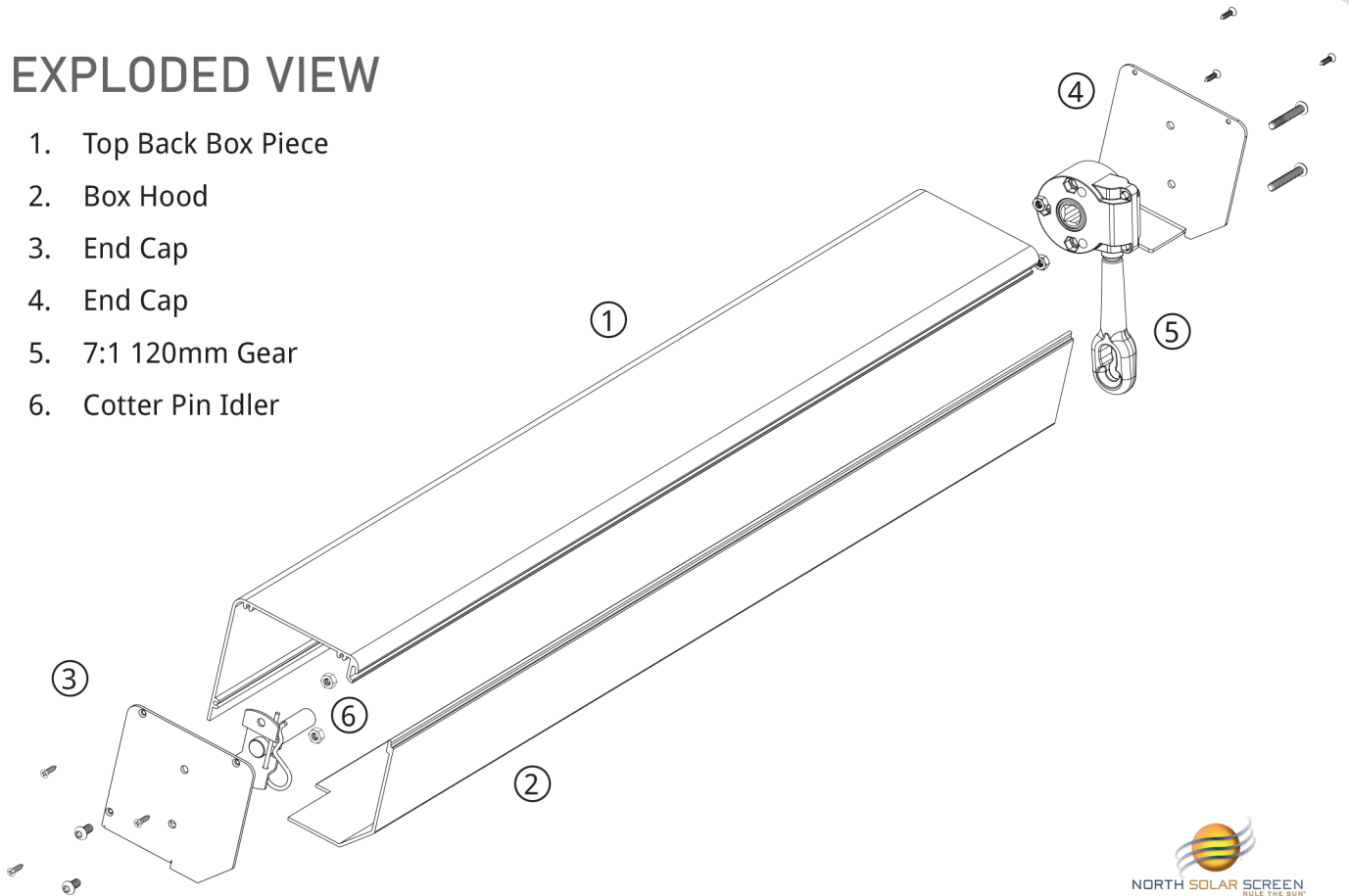

EXPLODED VIEW 80MM TUBE

1. 80mm Fabric Tube
2. FRT Idler Adapter
3. FRT Adapter

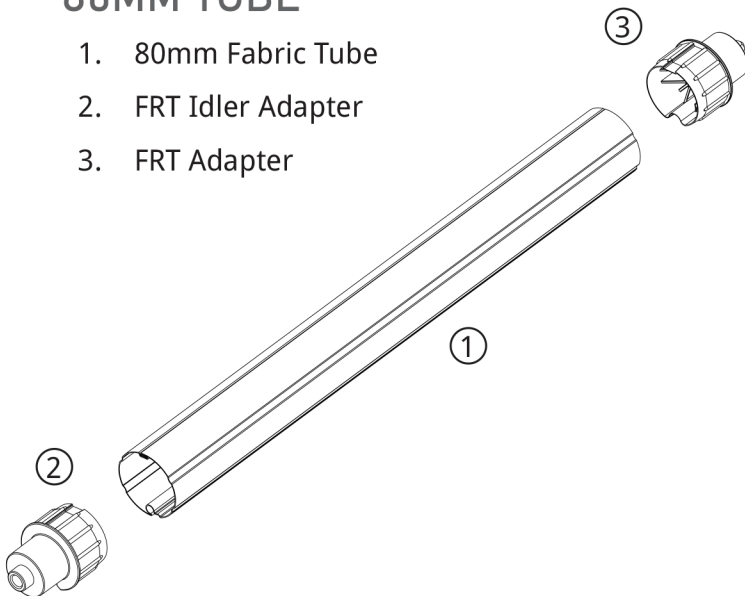

HOOD CLEARANCE

A minimum of 8" from face of wall/
beam required for hood clearance

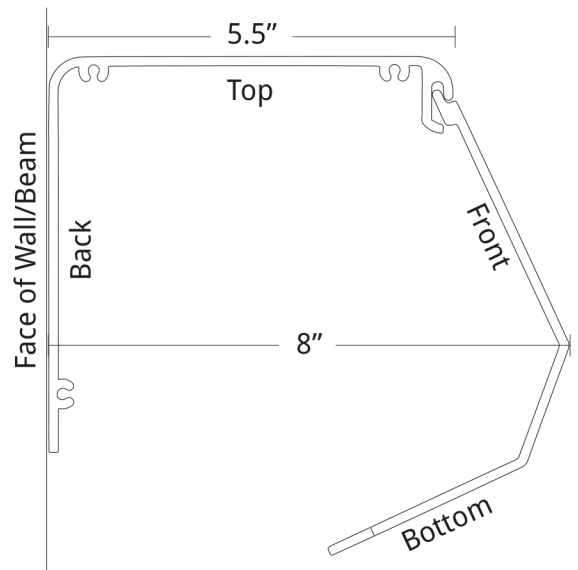

CITADEL BRAWNY™ ZIPPER TRACK TECHNICAL INFO

5.5" EXTRUDED ALUMINUM BOX

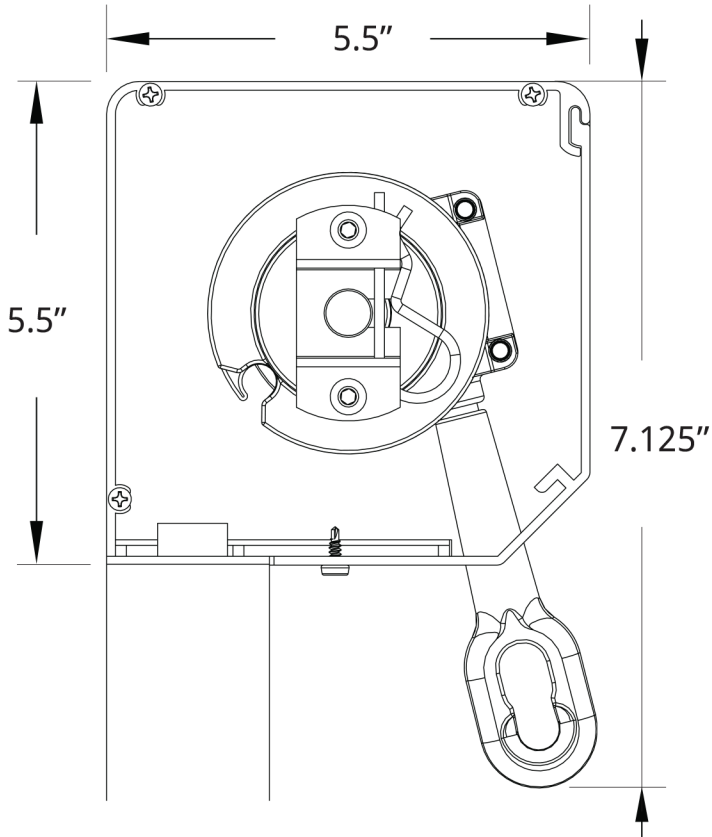

INTEGRATED WEIGHT BAR & TRACK SYSTEM

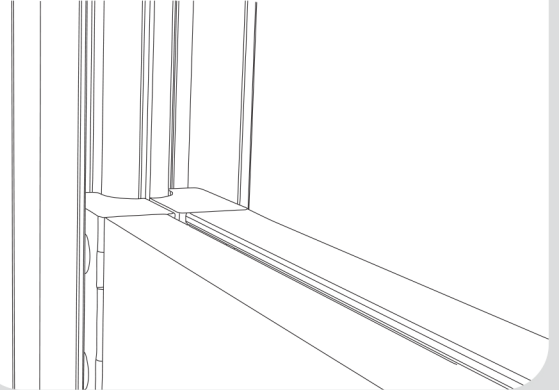

FUNNEL SYSTEM

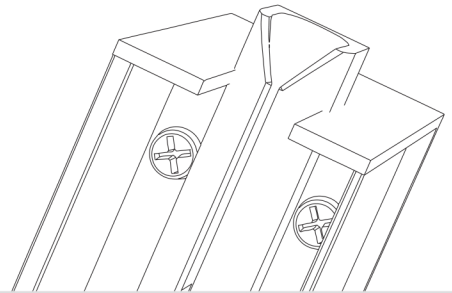

HEAVY DUTY FRT TRACK

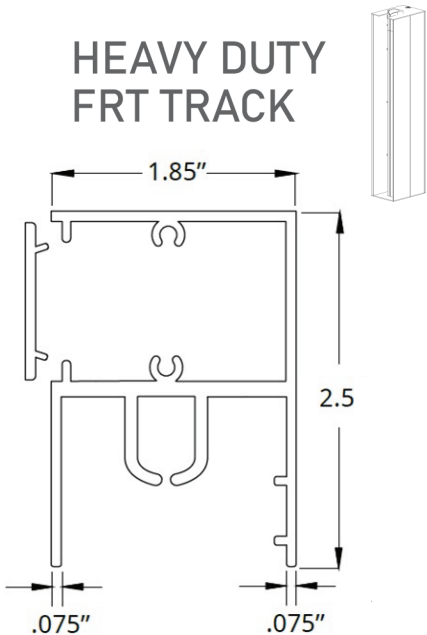

HEAVY DUTY FRT WEIGHT BAR

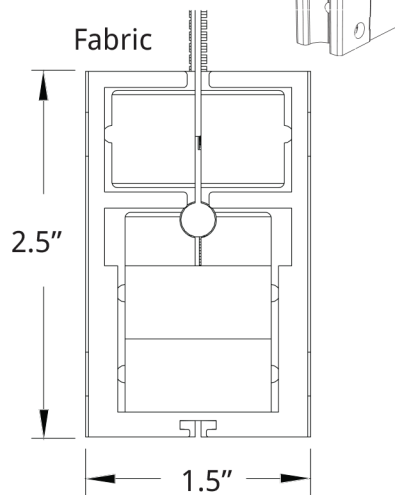

PILE BRUSHES

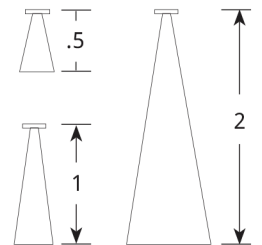

WEATHER SEAL

